



DEVELOPMENT AND IMPLEMENTATION OF A MINI CNC MILLING MACHINE

Tran Thanh Tung¹, Nguyen Xuan Quynh², Tran Vu Minh³

¹Faculty of Engineering Mechanics and Automation, University of Engineering and Technology, Vietnam
National University Hanoi, VietNam

tranthanhtung@vnu.edu.vn

^{2,3}Department of Manufacturing Technology, Ha Noi University of Science and Technology Ha Noi, Viet Nam
Address Including Country Name

²quynh.nguyenuan@hust.edu.vn

³minh.tranvu@hust.edu.vn

Abstract

The development of mechanical processing machines with integrated CNC systems allows the manufacturing industry to produce complex products quickly with high quality. CNC has become a main course for mechanical students in technical and vocational universities. CNC machine training is required to enhance student's skills to learning in design and manufacturing technology. However, the cost to buy a CNC machine is not cheap. In a developing country like Vietnam, along with the limited budget of most universities, this is an obstacle for students to have the opportunity to use CNC machines. To help students have a teaching aid in learning, improve practice capacity. The article proposes an alternative to design and manufacture a simple, inexpensive milling machine with all the required functions. The CAD models design of the machine model structure were done using Solidwork and NX software. Most of the machine's parts are manufactured and assembled in the Faculty of Engineering Mechanics and Automation laboratory of Engineering and Technology, Vietnam National University Hanoi. The study's main objective is to propose a process for designing and manufacturing a mini vertical 3-axis CNC milling machine with low cost but full features similar to an industrial CNC machine. The machine model introduced in the article can be used as a teaching aid, improving practical capacity for students of machine building

Keywords: CNC machine, milling machine, CAD/CAM

1. Introduction

Computer Numerical Control (CNC) is a kind of machine-controlled automatically with the aid of a computer. Parts are automatically programmed to operate according to the series of events set by the user to create a product of the required shape and size [1-3]. The industrial product formation cycle in a modern way uses the CAD/CAM/CNC method to design, manufacture, and assemble products, which is becoming the focus of research, development, and wide application in many countries worldwide. CAD (Computer-Aided Design) is a field of application of the computer to design. It assists designers in modeling, creating, and exporting design documents based on graphic techniques. CAM (Computer-Aided Manufacturing) is the next step between CNC machining and CAD design. When the product was entirely designed by CAD software, it was imported into CAM software to output programs for CNC machines to perform the machining process [4-6]. Generally, a CNC machine is complex with many high-precision manufactured parts that integrate many control systems [7-9].

CNC machine tools are controlled using a special type of code called G-code. CNC machine tools can be programmed directly through the keyboard and screen integrated on the machine or CAM software and then transferred to the computer via USB or other connections [10-12]. Today, integrated with many new and modern features, CNC machines increasingly play an essential role in machine manufacturing technology. Most commercial CNC machines are very bulky and complicated, so their cost is not cheap, making it very hard for universities, especially in developing countries like Vietnam, to invest in a CNC machine. Therefore, the mini CNC machine with affordable price but still full of basic learning functions gradually became popular [13-15]. The mini CNC milling machine is specially designed and used in classrooms, offices, or laboratories to help students improve their practical skills [16-17]. In addition, small CNC machines can still process products with high precision. Using small machines for production brings many advantages, saving space and electricity, less vibration, reduced noise, high flexibility, and easily relocated [18-19]. The main aims of the present work are the development, analysis, manufacture, and assessment of a cost-effective, easy-to-use, flexible, small-scale prototype 3-axis vertical CNC laboratory milling machine developed, which was developed for student experiments in CNC and CAD/CAM programming areas. The machine produced must have a simple interface, be easy to use, receive the common G-codec, have low power consumption, and be safe and durable. Prototypes produced have been calibrated and self-tested to meet industry standards.

2. Materials and methods

The CNC milling machine consists of two primary movements, the translational motion according to the X-Y of the table and the translational and rotational motion of the cutting tool. These movements were performed using sets of motors. In addition, the complete control unit of the machine includes control circuits and G-codes. Thus, the CNC milling machine fundamentally consists of mechanical components (main shaft, ball bearing, bearing, tool table, tool drive, lead screw, etc.) and an electrical system (including motor, control part, transmission parts

The primary design factors for building a CNC milling machine are shown in Figure 1. The device's dimensions in X, Y, Z correspond to 360 mm, 480 mm, and 340 mm, respectively.

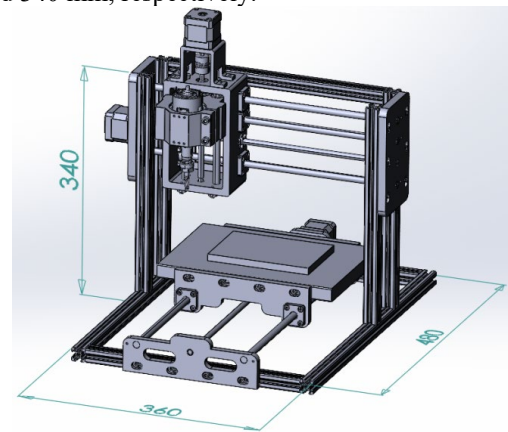

Fig. 1: The 3D prototype of the CNC milling machine

Different configurations are considered for the qualities; they offer better rigidity, better accuracy, simple operation, and simple programming. The power was calculate base on the suggestions in [16], as follow: the coefficient of friction, $\mu = 0.0025$. The screw diameter (d) = 14 mm, the table lead screw angle (α), pitch of leaf screw $p = 2$ mm

$$\mu = \tan\beta = 0.0025 \text{ and } \tan\alpha = \frac{p}{\pi d} = \frac{2}{\pi \times 14} = 0.045 \quad (1)$$

Assumption the maximum workpiece mass $m = 4$ kg, the external force is:

$$F_e = mg = 4 \times 9.81 = 39,2 \text{ N} \quad (2)$$

The frictional force is:

$$F_f = (9.81)\mu = 0.0981 \text{ N} \quad (3)$$

The total force

$$F = F_e + F_f = 39.3 \text{ N} \quad (4)$$

The tangential force is [20-21]:

$$F_t = F \times [\tan\alpha + \tan\beta] / [1 - \tan\alpha \times \tan\beta] = 1.864 \text{ N} \quad (5)$$

The torque required for the table screw rotation is:

$$T = F_t \times (d/2) + \mu F_t R = 1.864 \times 7 + 39.3 \times 7 \times 0.0025 = 13.74 \text{ N-mm} \quad (6)$$

The speed of the table lead screw $N = 40$ rpm and

$$P = T \times \omega = 0.137 \times 4.2 = 0.57544 \text{ W} \quad (7)$$

3. Manufacture of a CNC machine

Figure 2 shows the design of axes motions in CNC machine. Its structure had the Z-axis fixed in the study, and the workpiece was controlled to move up and down. The fixed part consists of the machine base and the Z-axis driving mechanism attachment. The workpiece is placed on the machine table and can move freely in the X- and Y-axis directions in the horizontal plane using the standard actuators. The motor is attached to the lead screw. The tool holder carries the machining tool to perform the movement in the Z-axis (vertical axis). To make a cost-effective CNC machine model, we choose the option of the workpiece to move in the Y-direction. It has the advantage of being easier to manufacture, and the machine part is also relatively compact, serving mainly in study and research.



Fig. 2: The stainless-steel linear movement guides rods

The workpiece plan moves on the Y axis, and the tool moves along the X and Z axes. The fixed part includes the machine frame (or platform), the sliding axes, the motor, and the transmission mechanism of the X and Y axes. Set of the machine frame consist in both X-axis and Y-axis attached on the sliders fixed to the structure, the Z-axis slides on the X-axis, so there is a slider, a motor, and a transmission mechanism of the Z-axis. On the Z-axis, there is a tool holder mechanism. The belt transmission is used to drive between the shafts in order to save costs, easy maintenance, and smooth operation, as shown in Figure 3.

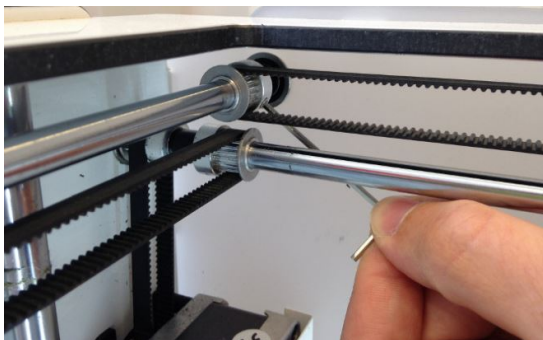

Fig. 3: The belt drive

Some CNC machine parts are fabricated by the 3D printing method, as illustrated in Figure 4, while some remaining components such as lead screws, nuts, and bearings are purchased as standard products available in the market.

Fig.4 : Fabricate some parts from 3D printer

4. The hardware and software system

For the optimization, cost savings and fabrication simplification, all circuits are standard in the market, including the Arduino Uno boards, as shown in Figure 4.

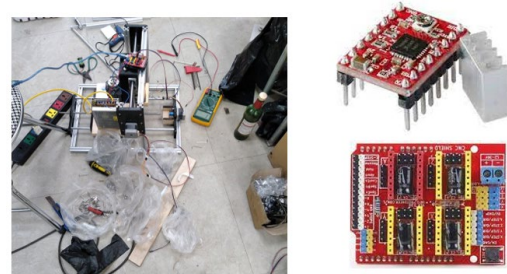

Fig.4 : The diagram for electronics system

With Arduino, we can build electronic applications that interact with each other through software and hardware support. For example, GRBL is an open-source software or trigger program that controls the movements of a CNC machine. We can easily install the GRBL program for Arduino to have a low-cost and high-performance CNC controller right away. GRBL uses G-code as an input signal, and an output signal is used to control motion via Arduino. Control board: Arduino CNC shield V3 is an expansion shield for Arduino Uno, allowing to control engraving machines. Laser, CNC milling machine, or mini 3D printer. Arduino CNC shield V3 enables control of up to 4 stepper motors via the A4988 or DRV8825 driver (with jumpers to control the stepper motor in the whole step, half step, 1/4, 1/8, or 1/16 mode). Shield Arduino CNC – to connect the stepper motor controller to the Arduino, the simplest way is to use the Arduino CNC shield. They use all the pins of the Arduino and provide the easiest way to connect to everything, stepper motors, spindles, limit switches, heatsinks. In terms of software, the machine uses the Arduino IDE (Arduino Integrated Development Environment), which is a text editor that helps users write code to load into the Arduino board.

5. Result and discussion

The complete model of the machine is shown in Figure 5. The machine is in good working order; there is no error in operation. The machine is easy to disassemble, convenient for replacing parts of the machine. When the machine is in process, the noise is not too loud, does not affect the surrounding environment, and does not cause pollution. The machine has full essential functions as an industrial

CNC machine (receiving G-code to run machining from CAM software) to fully meet students' learning and research needs.

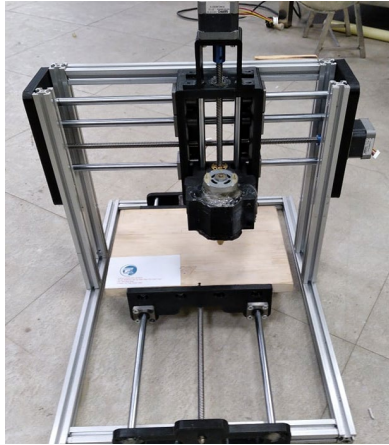

Fig. 5 : The final fabricated prototype milling machine assembly.

6. Conclusion

The article has introduced a mini CNC milling machine model to make visual aids for training in universities, colleges, and vocational schools. Basically, the study proposed a plan to design a mini-milling machine model and conduct processing. The machine model presented in the article can be assembled and disassembled according to the intended use to increase the machine's mobility and can be easily carried. Therefore, training institutions and production facilities with limited funds that cannot afford conventional milling can purchase this CNC milling machine to perform training and production activities efficiently.

References

- [1] Zhang, P. (2008), *Industrial Control Technology*, William Andrew Publishing, Elsevier.
- [2] da Rocha, P.A.S., de Silva e Souza R.D. and de Lima Tostes, M.E. (2010), *Prototype CNC machine design*, 9th IEEE/IAS International Conference on Industry Applications - INDUSCON, pp. 1-5.
- [3] Leon, A., Suess, T. and Lawson, D. (2001), *Building a CNC-capable metal 3D printing lab*, Metal Powder Report.
- [4] Hidayanti, N., Ambrizala, B., Farooqib, A., Alsultanc, O.I. and Yusoffd, B. (2017), *Design and Development of CNC Robotic Machine Integrate-able with Nd-Yag Laser Device*, *Procedia Engineering*, vol. 184, pp 145–155.
- [5] Xiao, Y., Jiang, Z., Gu, Q., Yan, W., and Wang, R. (2021), *A novel approach to CNC machining center processing parameters optimization considering energy-saving and low-cost*, *Journal of Manufacturing Systems*, vol. 59, pp. 535-548,
- [6] Rocha, P., Tostes, E. (2018), *Development of an Embedded CNC Control System*, *Industry Applications (INDUSCON) 13th IEEE International Conference on*, pp. 407-412.
- [7] Srinivasan, V.P., Abhilash Arulvalan, J. Amarnath, L. Dhinesh, R.B. Dhivyan, F. Mohammed Rizwan, A. Navashanmugam, P. Mowyanivesh. (2021), *Design and fabrication of dual axis writing machine*, *Materials Today: Proceedings*, vol. 45(7), pp. 6743-6749.
- [8] Sevic, M., Keller, P. (2019), *Design of CNC Milling Machine as a Base of Industry 4.0 Enterprise*. *MM Science Journal*, vol. 12, pp. 3555-3560.
- [9] Gupta, M., Goswami, C., Khandelwal, N. (2021), *Design and structural analysis of 3-sided and 4-sided columns of a CNC machine using finite element analysis*, *Materials Today: Proceedings*, in press.
- [10] Latif, K., Adam, A., Yusof, Y. AND Kadir. A.z.a. (2010), *A review of G code STEP STEP-NC and open architecture control technologies based embedded CNC systems*, *The International Journal of Advanced Manufacturing Technology*, vol. 114(2), pp. 2549-2566.
- [11] Sun, S., Altintas, Y. (2010), *A G3 continuous tool path smoothing method for 5-axis CNC machining*, *CIRP Journal of Manufacturing Science and Technology*, vol. 32, pp 529-549.
- [12] Aciu R. and Ciocarlie, H. (2014), *G-code optimization algorithm and its application on Printed Circuit Board drilling*, *IEEE 9th IEEE International Symposium on Applied Computational Intelligence and Informatics (SACI)*, pp. 43-47.
- [13] Duong, T.H., Jaksic, N.I., DePalma, J.L., Ansaf, B., Daniel, M., Armijo, J. and Galaviz, M. (2018), *G-code Visualization and Editing Program for Inexpensive Metal 3D Printing*, *Procedia Manufacturing*, vol. 17, pp. 22-28.
- [14] Müller, M. and Wings, E. (2016), *An Architecture for Hybrid Manufacturing Combining 3D Printing and CNC Machining*. *International Journal of Manufacturing Engineering*, 8609108.
- [15] Dhandapani, N.V., Thangarasu, V.S. and Sureshkannan, G. (2015), *Investigation on Effect of Material Hardness in High Speed CNC End Milling Process*. *The Scientific World Journal*, 762604.

- [16] Saad, M.A. and Haider, M.(2010), *Design and Fabrication of 3-Axes Mini CNC Milling Machine*. IOP Conference Series: Materials Science and Engineering, 1094 012005.
- [17] Bangse, K., Wibolo, A., and Wiryanta, I.K. (2020), *Design and Fabrication of a CNC Router Machine for Wood Engraving*. Journal of Physics: Conference Series, vol. 1450, pp. 1–7.
- [18] Milica, K., Aleksandar, K., Nemanja, B., Mihajlo, S. and Gordana, G. (2014), *Design of Laboratory 3-Axes CNC Milling Machine by Modular Approach LABROS 100S“ A ACTA Tehnica Corviniensis, Bulletin of Engineering*, vol 7, no. 1, pp. 123–126.
- [19] Rastvorova, I.I, and Klyucherev, N.A. (2021), *Design and modelling of a universal CNC machine*. Journal of Physics: Conference Series 1753.
- [20] Isakov, E. (2012), *Understanding tangential cutting force when milling*. Cutting tool engineering Plus, vol. 64, Issue 5.
- [21] Lapsomthop, W., Wongsirirax, N., Kititeerakol, A., Sawangsri, W. (2019), *Design and experimental investigation on 3- component force sensor in mini CNC milling machine*, Materials Today: Proceedings, vol. 17, part 4.